

Your Water. Perfected.

Let us

Perfect

your water and

Protect

your family.

ERO 175

ECOWATER REVERSE OSMOSIS – DRINKING WATER SYSTEM

Reverse Osmosis Drinking Water System

Reverse Osmosis (RO) drinking water systems provide high-quality water for worry-free living. Improve the quality of your well or municipal water with the EcoWater ERO 175.

Get bottled water quality in the convenience of your own home. No need to lift heavy bottled water. The EcoWater ERO 175 provides great tasting water for all your cooking and drinking water needs.

Here's How an RO Works:

- 1 Household water is directed through a prefilter for filtration to remove sediment, chlorine taste and odor, and particulate matter.
- 2 The water is then forced, by pressure, through a semi-permeable membrane where a high percentage of the dissolved solids, etc. are rejected and flushed to the drain.
- 3 Filtered water is reserved in the storage tank until needed. An activated carbon absorption block filter that removes tastes and odors polishes the water immediately before going to the faucet.

Features:

- Three-stage filtering process: carbon sediment filter, RO membrane; and a carbon post filter to polish the water before you drink it
- Durable chrome-colored faucet
- NSF tested and certified



 Designed, Engineered & Assembled in the U.S.A.

ecowater.com

ERO 175

ECOWATER REVERSE OSMOSIS DRINKING WATER SYSTEM

DIMENSIONS

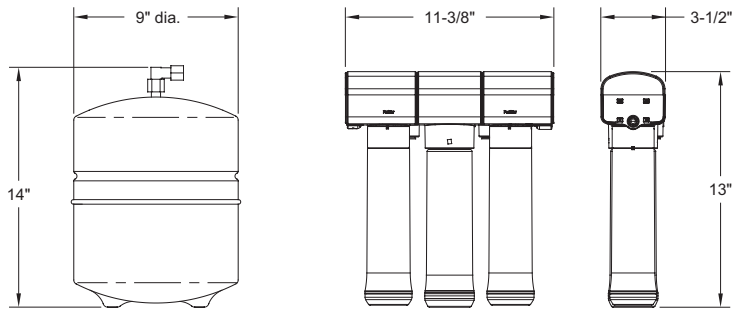

SPECIFICATIONS

	ERO 175
Feed water pressure (min.-max.)	40-100 psi
Feed water temperature (min.-max.)	40-100°F/4-38°C
Maximum Total Dissolved Solids (TDS)	2,000 ppm
Membrane percent rejection of TDS (min.)	91%
System product water production rate (gal. per day)*	18.4
Feed water pH limits	4-10 pH
Maximum iron	0
Maximum hydrogen sulfide	0
Maximum manganese	0
Type of membrane	thin film composite
Prefilter (sediment/carbon)	block carbon
Postfilter (taste and odor)	block carbon
Storage tank size	3 gal.
Automatic shut off valve	yes
Shipping weight	13 lbs.

*Tested to NSF/ANSI Standard 58.

Typical impurities reduced by an EcoWater Reverse Osmosis Drinking Water System Model ERO 175 System.

- Ammonium¹
- Arsenic
- Barium
- Bicarbonate¹
- Bromide¹
- Cadmium
- Chloride¹
- Chromium (Hex)
- Chromium (Tri)
- Chlorine Taste & Odor
- Copper
- Cysts (Giardia/Cryptosporidia)
- Fluoride
- Lead
- Magnesium¹
- Nitrate/Nitrite
- Radium 226/228
- Selenium
- Sodium¹
- Sulfate¹
- Tannin¹
- TDS
- Turbidity
- Zinc¹

Tested and Certified to NSF/ANSI Standard 58 by NSF International.

Rated at 50 psi, 77 F, 750 ppm/TDS, product to storage tank.

Product water produced, amount of waste water and percent rejection will vary with changes in pressure, temperature and total dissolved solids.

¹Tested by Spectrum Labs, Inc. a state certified testing laboratory.

ERO 175: For municipal and well water supplies. Chlorine must not exceed 2.0 ppm.

WARRANTY

- One year on the reverse osmosis drinking water system for defects in material and workmanship.
- Five years on the storage tank.
- Filter cartridges are not covered. The service life of the membrane and filter cartridges is dependent on the feedwater quality.

ECOWATER
SYSTEMS®



Your Water. Perfected.

MS2

